



BINDER CLUTCHES & BRAKES

SPRING-APPLIED SINGLE-DISC BRAKE MODULE

77 500..A15



MODULE LINE

POWER OF PARTNERSHIP AND MAGNETISM

Kendrion Power Transmission

BINDER CLUTCHES & BRAKES

Our company's strength is measured by the delivery of products, performances, as well as a high degree of esteem towards our customers. KENDRION POWER TRANSMISSION is striving to develop a long-term relationship with its

customers and to cultivate this relationship under the motto "Power of Partnership". Ambitious aims can only be realised through a close and productive co-operation with our customers.

The development of high-quality standard products as well as optimised tailor made solutions is the foundation of all our actions.

Power of Partnership stands for a co-operation with the Kendrion employees without bureaucracy, ensuring a long and successful partnership with our customers.

Top Market Knowledge...

the realisation of market orientated products are the results of our competence in electromagnetism which has been achieved with decades of experience and knowledge. The development of most innovative concepts and the

use of the most modern technologies in our research department together with the use of the latest production and logistic processes are our strengths.

Our customers profit from the individual solutions for high volume as well as the availability of individual products on the basis of a standard platform.

Our know-how is growing steadily hand in hand with the constant optimisation of every business process.

Optimal tailor made solutions...

are not empty promises. The profound understanding of the Power of Magnetism at KENDRION POWER TRANSMISSION is the source of the research/development of market orientated products. Continuous expansion of the technological possibilities

enables us to be in the position to offer optimal solutions of brakes and clutches for numerous applications. We lay great emphasis on being able to offer solutions for different applications such as:

- ... SECURING
- ... STOPPING
- ... POSITIONING
- ... ACCELERATING.

Important synergies as a basis for success...

KENDRION POWER TRANSMISSION is a European company with a local presence in all economic regions of the world. Integrated in and yielding performance to the Kendrion Holding N.V., which is noted on the Amsterdam stock exchange, as a successful company with an annual turnover of 1,8 billion EUR; and approx. 5500 employees all over the world.

This is an excellent basis to realise, secure and enable our long-term goals and company objectives. A network of connected companies within Kendrion is another valuable factor for the success of KENDRION POWER TRANSMISSION. We live the "Power of Partnership" in a firm exchange

of expertise and business relationship within these companies.



Kendrion Power Transmission protects people and the environment

General technical information

77 500..A15

Clutch or brake design and rating, calculation example

look at www.KendrionAT.com

Product line information

BINDER CLUTCHES & BRAKES

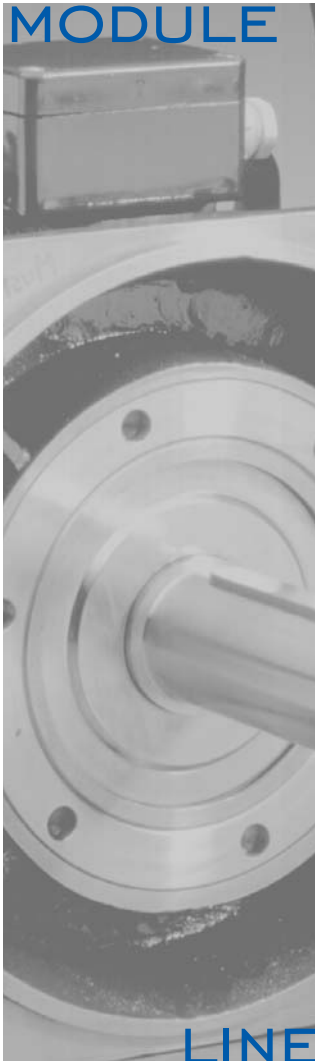

The MODULE LINE is comprised of DC operated spring-applied single-disc brake modules designed to be mounted on a fully assembled motor. The brake modules should preferably be attached to the A-face end shield of the motor. All MODULE LINE brake units are equipped with a supported shaft + drive. MODULE LINE brakes are designed as fail-safe holding brakes with emergency stop function. Electromagnetic spring-applied brakes generate the required braking torque when voltage is removed. The braking effect can be neutralised by an electromagnetic force or by an additional hand release feature during set-up work.

Applications

- DC motors
- Gear motors
- IEC three-phase motors
- Servo motors
- ...

Versions

77 500..A15	torque range 25-500 Nm DC adjustable torque attachable brake module (holding brake)
-------------	---

Upon request, the brake can be supplied with variable connection features (e.g. cables, connection box with built-in half-wave rectifier or overexcitation rectifier).

Information on technical data included in the data sheets

The information provided in the operating instructions must be strictly adhered to when designing a machine (e.g. motor) and when using the brakes. The brakes are manufactured and tested in compliance with DIN VDE 0580 requirements. The insulation materials used conform with thermal class F norms. The specified times apply to the following conditions: separate switching of the brake, operating temperature, rated voltage, and rated air gap. All values are mean values that are subject to variation. In the case of AC brake switching, the

coupling time t_1 is substantially longer. W_{max} (maximum switching energy) is the switching energy that must not be exceeded during braking operations at max. 1500 rpm. Braking operations at > 1500 rpm lead to a substantial reduction in the maximum admissible switching energy per switching operation (see diagram included in operating instructions). The maximum switching power P_{max} is the switching energy W that can be converted by the brake per hour. The permitted number of switching operations Z (emergency stops) per hour and

the max. permitted switching energy W_{max} resulting therefrom are specified in the table included in the operating instructions. If the brake is used for other applications, e.g. as service brake, the diagram (W_{max} as a function of the number of switching operations per hour Z) shown in the operating instructions applies. The P_{max} and W_{max} values are approximate values; they apply to applications where the brake is attached to a motor equipped with fan and to speeds of 1500 rpm. The specified transmissible torques M_4 characterise the torque level of

the brakes. Depending on the application of the brake, the switching torque M_1 and the effective transmissible torque M_4 may differ from the specified M_4 values. The switching torque M_1 depends on the speed (rpm). If the friction surfaces are contaminated with oil, grease or dirt the transferable torque M_4 and the switching torque M_1 may drop.

All technical data is subject to the running-in process of the brake being completed. Vertical operation of the brake is only permitted after prior consultation with the manufacturer.

SPRING-APPLIED SINGLE-DISC BRAKE

DC



Photo: 77 50019A15

Version	77 500..A15
Standard rated voltages	24 V, 102 V, 178 V DC
Protection	IP 55
Thermal class	F
Rated torques	25 - 500 Nm
Accessories (options)	hand release feature

Specification subject to change without notice.
The "General technical information" and the "Operating instructions" 77 500..A15 must be strictly observed.

Technical data

Size	Transmissible torque range (standard)	Max. reachable transmissible torque with fully screwed in adjusting ring	Max. speed	Max. switching power	Max. switching energy (Z=1)	Rated power	Response times		Moment of inertia hub and friction disc	Weight
							on	off		
	M ₄ [Nm]	M _{4 max} [Nm]	n _{max} [rpm]	P _{max} [kJ/h]	W _{max} [kJ]	P _N [W]	t ₁ [ms]	t ₂ [ms]	J [kgcm ²]	m [kg]
13	25 - 55	55	6000	40	15	97	30	110	9.3	10
19	60 - 150	155	5500	160	60	131	60	260	48	21
24	140 - 310	310	4500	260	150	167	100	330	141	46
29	280 - 500	520	3700	400	275	190	450	350	266	66

The service life values (W_{tot}) specified in the table refer to the maximum transmissible torque (standard).

Ordering data (to be fully specified)

SPRING-APPLIED SINGLE-DISC BRAKE		BRAKE SHAFT	
Please specify requested version			
1	Size (19, 24, 29), size 13 upon request Size: _____	1	Size (13, 19, 24, 29) Size: _____
2	Coil voltage (standard 24V, 102V, 178 V) Voltage: _____ V DC	2	Shaft end (standard), groove N9 as per DIN 6885, sheet 1 Size 13: Ø32 _{k6} x 58 mm Size 19: Ø38 _{k6} x 80 mm Size 24: Ø42 _{k6} x 110 mm Size 29: Ø55 _{m6} x 110 mm Shaft end: _____ mm
3	Transmissible torque M ₄ (standard) Gr. 13: 55 Nm Gr. 19: 150 Nm Gr. 24: 310 Nm Gr. 29: 500 Nm Transmissible torque M ₄ : _____ Nm	3	Bore diameter (standard) Size 13 Ø32 mm (for shaft Ø32 _{k6} x 58 mm) Size 19 Ø38 mm (for shaft Ø38 _{k6} x 80 mm) Size 24 Ø42 mm (for shaft Ø42 _{k6} x 110 mm) Size 29 Ø55 mm (for shaft Ø55 _{m6} x 110 mm) Bore diameter: _____ mm
4	Microswitch <input type="checkbox"/> with microswitch <input type="checkbox"/> without microswitch		

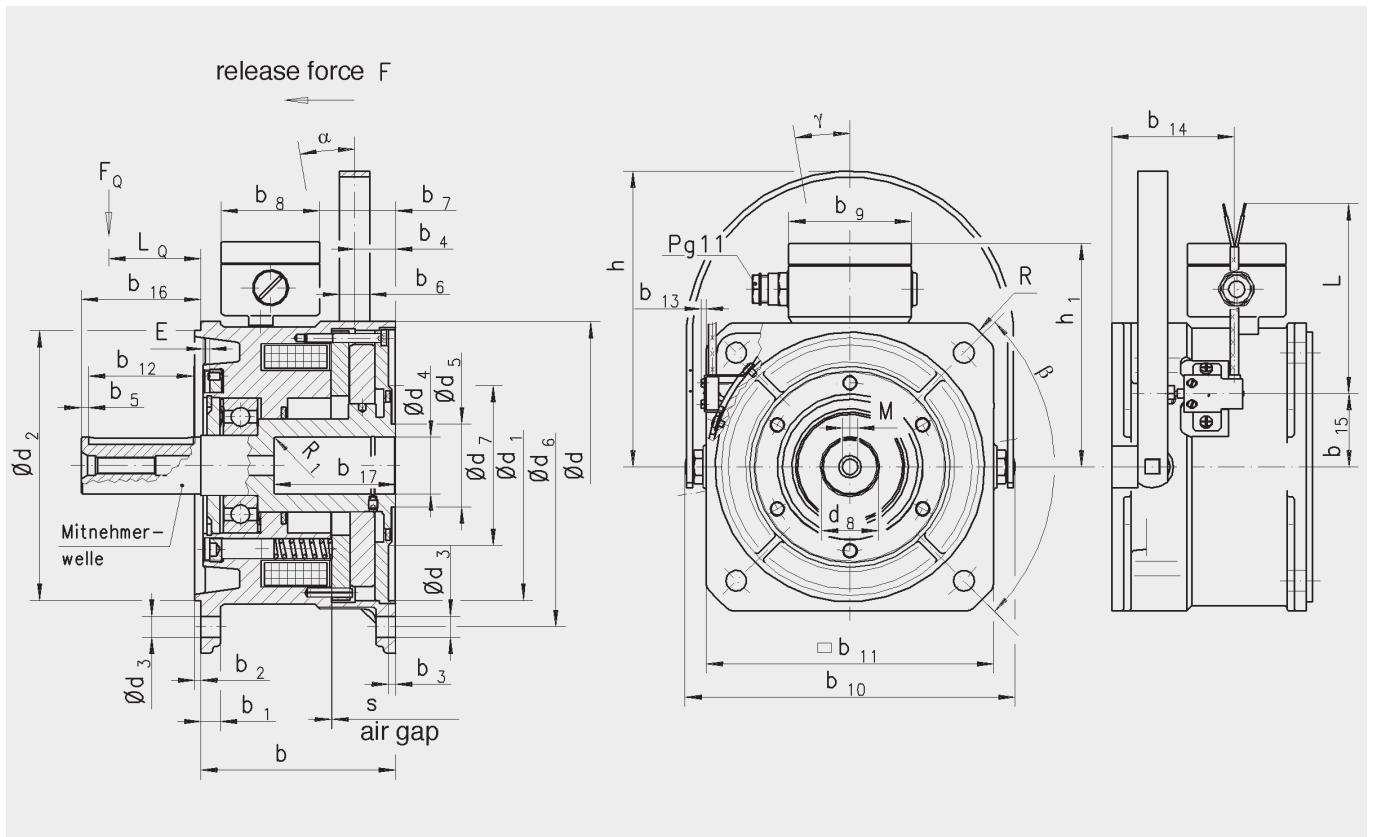

Size	d	d ₁ (+0.15)	d ₂	d ₃	d ₄	d ₅	d ₆	d ₇	d ₈	b(-0.08)	b ₁	b ₂	b ₃	b ₄	b ₅	b ₆	b ₇	b ₈	b ₉	b ₁₀	b ₁₁	b ₁₂
13	142	130.3	130 _β	11	28 ¹ /32 ²	45	165	84	28 ³ /32 ⁰	103	13	3.5	4.1	22	5	20	25	66	82	164	142	45
19	192	180.3	180 _β	14	32 ¹ /38 ²	55	215	108	32 ³ /38 ⁰	130	13	4	4.5	27	5	20	50.5	66	82	221	192	70
24	248	250.3	250 _{h6}	18	42 ¹ /48 ²	66	300	132	42 ³ /48 ⁰	162	18	5	5.8	37	10	25	60	66	82	278	260	90
29	298	300.3	300 _{h6}	18	50 ¹ /55 ²	77	350	135	50 ³ /55 ⁰	168	18	5	5.8	41	10	25	79	66	82	329	314	90

Size	b ₁₃	b ₁₄	b ₁₅	b ₁₆	b ₁₇	h	h ₁	R	R ₁	L	L _Q	s	s _{max}	M	F [§] [N]	F _Q [§] [N]	α	β	γ
13	5.5	70	35	58	53	162	122	96	2	508	58	0.3 ⁺ 0.2	0.65	M12	80	1100	ca.20°	4x90°	9.5°
19	3	80	48.5	80	81	224	149	125	2	508	80	0.35 ⁺ 0.2	0.8	M12	130	2300	ca.19°	4x90°	0°
24	-6	94	60.5	110	111	269	174	175	2	508	110	0.4 ⁺ 0.25	1.05	M16	200	2000	ca.17°	4x90°	0°
29	-13	101	72.5	110	111	328	199	200	2	508	110	0.45 ⁺ 0.25	1.2	M20	240	6800	ca.19°	4x90°	0°

1) Min. bore.
 2) Max. bore.
 3) Min. shaft diameter.

4) Max. shaft diameter.
 5) Release force F (approx.) referred to max. transmissible torque (standard).
 6) Max. permitted transverse force with distance L_Q.

Accessories

Size	Hand release feature
13	76 14113B00940
19	76 14119B00940
24	76 14124B00940
29	77 50029A00940



Kendrion Binder Magnete GmbH
Industrial Drive Systems
Mönchweilerstrasse 1
78048 Villingen-Schwenningen
Germany

Phone: +49 7721 877 -1417
Fax: +49 7721 877 -1462

www.kendrion-electromagnetic.com
sales-ids@kendrion.com

Contact details of our subsidiaries and
distributors can be found on our website.

MODULE LINE

MODULE LINE

POWER OF PARTNERSHIP AND MAGNETISM